

**TECHNICAL MANUAL**

**OPERATOR, ORGANIZATIONAL, DIRECT SUPPORT  
AND GENERAL SUPPORT MAINTENANCE  
MANUAL INCLUDING REPAIR PARTS LIST**

**FOR**

**GUN, CLEANING, PNEUMATIC,  
MODEL 140B2**

**(NSN 4940-00-910-2687)**



TECHNICAL MANUAL }  
No. 9-4940-420-14&P }

HEADQUARTERS  
DEPARTMENT OF THE ARMY  
WASHINGTON, DC, 31 December 1979

**OPERATORS, ORGANIZATIONAL, DIRECT SUPPORT AND  
GENERAL SUPPORT MAINTENANCE MANUAL  
INCLUDING REPAIR PARTS LIST  
FOR  
GUN, CLEANING, PNEUMATIC, MODEL 140B2  
(BINKS MANUFACTURING COMPANY)  
(NSN 4940-00-910-2687)**

**REPORTING OF ERRORS**

**You can improve this manual by recommending improvements using DA Form 2028 (Recommended Changes to Publications and Blank Forms) or DA Form 2028-2 located in the back of the manual and mail the form to Commander, US Army Armament Materiel Readiness Command, ATTN: DRSAR-MAS, Rock Island, IL 61299. A reply will be furnished direct to you.**

**NOTE**

This manual is published for the purpose of identifying an authorized commercial manual for the use of the personnel to whom the cleaning gun is issued.

Manufactured by: Binks Manufacturing Company  
9201 W. Belmont Ave.  
Franklin Park, IL 60131

Procured under Contract No. DAAA09-75-M8338

This technical manual is an authentication of the manufacturers' commercial literature and does not conform with the format and content specified in AR 310-3, Military Publications. This technical manual does, however, contain available information that is essential to the operation and maintenance of the equipment.



CAUTION

Provide adequate ventilation and be alert to possible fire hazards when spraying cleaning solvents.

INTRODUCTION

The cleaning gun is used for spraying automotive equipment, motors, machinery and parts with cleaning solvent. The cleaning solvent is SIPHONED from a container. FLUID FLOW can be CHANGED by increasing or decreasing the air pressure and also by adjusting the 57-92 NOZZLE.

NOTE

MAXIMUM AIR INLET PRESSURE not to exceed 150 psi.

LUBRICATION

Monthly, oil (1 or 2 drops) 57-99 stem to lubricate 82-158 Packing.

MODEL 140-B2 GUN; SPRAY, SOLVENT

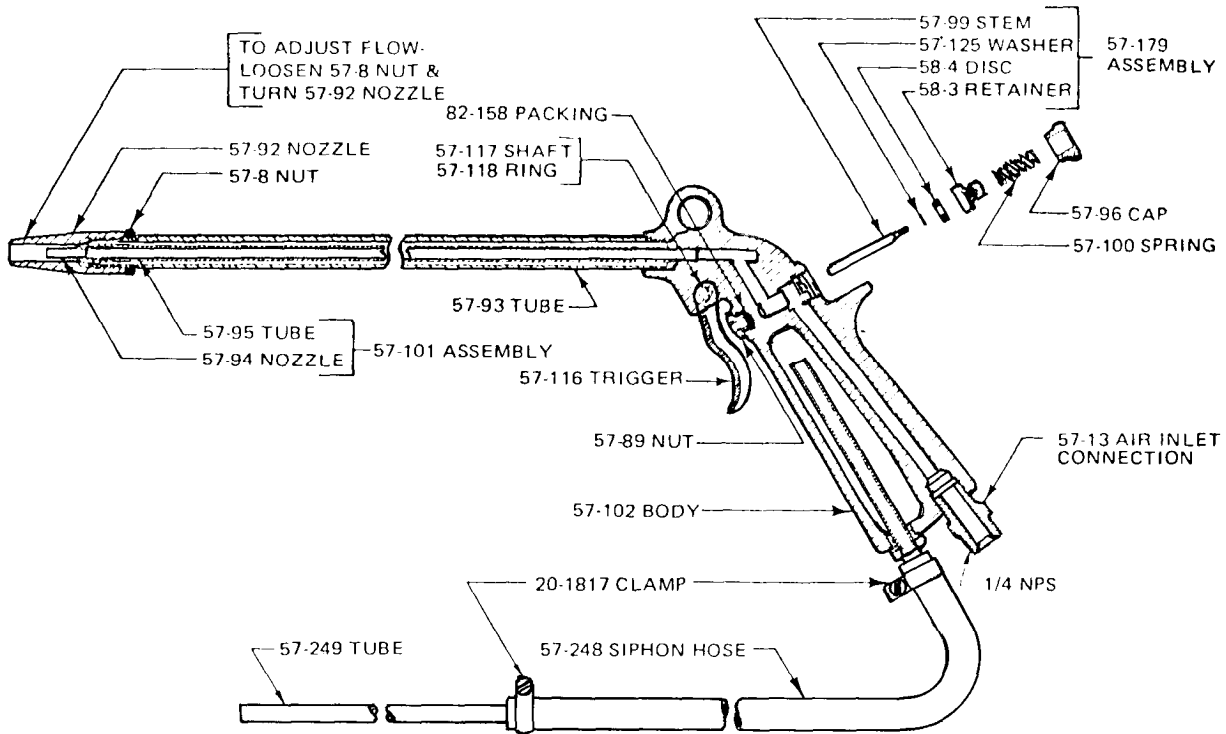

PARTS LIST

PART NO.	DESCRIPTION	QTY.	PART NO.	DESCRIPTION	QTY.
20-1817	HOSE CLAMP	2	57-101	AIR TUBE ASSEMBLY	1
57-8	NOZZLE LOCKNUT	1	57-102	BODY ASSEMBLY	1
57-13	AIR CONNECTION	1	57-116	TRIGGER	1
57-89	PACKING NUT	1	57-117	TRIGGERSHAFT	1
57-92	OUTSIDE NOZZLE	1	57-118	SNAP RING	2
57-93	OUTSIDE TUBE	1	57-125	WASHER	1
57-94	NOZZLE	1	57-179	AIR VALVE ASSEMBLY	1
57-95	TUBE	1	57-248	SUCTION HOSE, 1/4" I.D. x 7'-6" LONG.	1
57-96	AIR VALVE CAP	1	57-249	TUBE 18" LONG	1
57-99	AIR VALVE STEM	1	58-3	VALVE DISC RETAINER	1
57-100	AIR VALVE SPRING	1	58-4	VALVE DISC	1
			82-158	PACKING	2

PRINTED IN USA 5/75

**INSTRUCTIONS FOR REQUISITIONING PARTS  
NOT IDENTIFIED BY NSN**

When requisitioning parts not identified by National Stock Number, it is mandatory that the following information be furnished the supply officer.

- 1-Manufacturer's Federal Supply Code Number-
- 2-Manufacturer's Part Number exactly as listed herein.
- 3-Nomenclature exactly as listed herein, including dimensions, if necessary,
- 4-Manufacturer's Model Number-
- 5-Manufacturer's Serial Number (End Item)
- 6-Any other information such as Type, Frame Number, and Electrical Characteristics, if applicable.
- 7-If DD Form 1348 is used, fill in all blocks except 4, 5, 6, and Remarks field in accordance with AR 725-50.

Complete Form as Follows:

(a) In blocks 4, 5, 6, list manufacturer's Federal Supply Code Number followed by a colon and manufacturer's Part Number for the repair part.

(b) Complete Remarks field as follows:

Noun: (nomenclature of repair part)

For: NSN

Manufacturer:

Model:

Serial:

Any other pertinent information such as frame number, type, dimensions, etc.





By Order of the Secretary of the Army

Official:

J. C. PENNINGTON  
*Major General, United States Army*  
*The Adjutant General*

E. C. MEYER  
*General United States Army*  
*Chief of Staff*



RECOMMENDED CHANGES TO EQUIPMENT TECHNICAL PUBLICATIONS



THEN... JOT DOWN THE DOPE ABOUT IT ON THIS FORM. CAREFULLY TEAR IT OUT, FOLD IT AND DROP IT IN THE MAIL!

SOMETHING WRONG WITH THIS PUBLICATION?

FROM: (PRINT YOUR UNIT'S COMPLETE ADDRESS)

DATE SENT

PUBLICATION NUMBER

TM 9-4940-420-14&P

PUBLICATION DATE

31 Dec 79

PUBLICATION TITLE

Gun, Cleaning, Pneumatic, Model 140B2

BE EXACT... PIN-POINT WHERE IT IS

PAGE NO.

PARA-GRAPH

FIGURE NO.

TABLE NO.

2

11

IN THIS SPACE TELL WHAT IS WRONG AND WHAT SHOULD BE DONE ABOUT IT:

Part No. "5-34 Air Spray Nozzle," should be changed to read "5-32 Air Nozzle."  
Reason: Wrong part nomenclature.

Under "Set Up - Caution," change "80 cycles" to read "60 cycles."  
Reason: Wrong cycle designation.

SAMPLE

PRINTED NAME, GRADE OR TITLE, AND TELEPHONE NUMBER

John Doe, SP/4

SIGN HERE:

*John Doe*

TEAR ALONG PERFORATED LINE

FILL IN YOUR  
UNIT'S ADDRESS

FOLD BACK

DEPARTMENT OF THE ARMY

POSTAGE AND FEES PAID  
DEPARTMENT OF THE ARMY  
DOD 314



TEAR ALONG PERFORATED LINE

OFFICIAL BUSINESS  
PENALTY FOR PRIVATE USE \$300

Commander  
US Army Armament Materiel Readiness Command  
ATTN: DRSAR-MAS  
Rock Island, IL 61299

RECOMMENDED CHANGES TO EQUIPMENT TECHNICAL PUBLICATIONS



THEN... JOT DOWN THE DOPE ABOUT IT ON THIS FORM, CAREFULLY TEAR IT OUT, FOLD IT AND DROP IT IN THE MAIL!

SOMETHING WRONG WITH THIS PUBLICATION?

FROM: (PRINT YOUR UNIT'S COMPLETE ADDRESS)

DATE SENT

PUBLICATION NUMBER

TM 9-4940-420-14&P

PUBLICATION DATE

31 Dec 79

PUBLICATION TITLE

Gun, Cleaning, Pneumatic, Model 140B2

BE EXACT... PIN-POINT WHERE IT IS

PAGE NO.

PARA-GRAPH

FIGURE NO.

TABLE NO.

IN THIS SPACE TELL WHAT IS WRONG AND WHAT SHOULD BE DONE ABOUT IT:

TEAR ALONG PERFORATED LINE

PRINTED NAME, GRADE OR TITLE, AND TELEPHONE NUMBER

SIGN HERE:

FILL IN YOUR  
UNIT'S ADDRESS

FOLD BACK

TEAR ALONG PERFORATED LINE

DEPARTMENT OF THE ARMY

POSTAGE AND FEES PAID  
DEPARTMENT OF THE ARMY  
DOD 314



OFFICIAL BUSINESS  
PENALTY FOR PRIVATE USE \$300

Commander  
US Army Armament Materiel Readiness Command  
ATTN: DRSAR-MAS  
Rock Island, IL 61299

RECOMMENDED CHANGES TO EQUIPMENT TECHNICAL PUBLICATIONS



THEN... JOT DOWN THE DOPE ABOUT IT ON THIS FORM, CAREFULLY TEAR IT OUT, FOLD IT AND DROP IT IN THE MAIL!

**SOMETHING WRONG WITH THIS PUBLICATION?**

FROM: (PRINT YOUR UNIT'S COMPLETE ADDRESS)

DATE SENT

PUBLICATION NUMBER

TM 9-4940-420-14&P

PUBLICATION DATE

31 Dec 79

PUBLICATION TITLE

Gun, Cleaning, Pneumatic, Model 140B2

BE EXACT... PIN-POINT WHERE IT IS

PAGE NO

PARA-GRAPH

FIGURE NO

TABLE NO

IN THIS SPACE TELL WHAT IS WRONG AND WHAT SHOULD BE DONE ABOUT IT:

TEAR ALONG PERFORATED LINE

PRINTED NAME, GRADE OR TITLE, AND TELEPHONE NUMBER

SIGN HERE:

FILL IN YOUR  
UNIT'S ADDRESS

FOLD BACK

DEPARTMENT OF THE ARMY

POSTAGE AND FEES PAID  
DEPARTMENT OF THE ARMY  
DOD 314



CUT ALONG PERFORATED LINE

OFFICIAL BUSINESS  
PENALTY FOR PRIVATE USE \$300

Commander  
US Army Armament Materiel Readiness Command  
ATTN: DRSAR-MAS  
Rock Island, IL 61299



RECOMMENDED CHANGES TO EQUIPMENT TECHNICAL PUBLICATIONS



THEN... JOT DOWN THE DOPE ABOUT IT ON THIS FORM. CAREFULLY TEAR IT OUT. FOLD IT AND DROP IT IN THE MAIL!

**SOMETHING WRONG WITH THIS PUBLICATION?**

FROM: (PRINT YOUR UNIT'S COMPLETE ADDRESS)

DATE SENT

PUBLICATION NUMBER

TM 9-4940-420-14&P

PUBLICATION DATE

31 Dec 79

PUBLICATION TITLE

Gun, Cleaning, Pneumatic,  
Model 140B2

BE EXACT... PIN-POINT WHERE IT IS

PAGE  
NO.

PARA-  
GRAPH

FIGURE  
NO.

TABLE  
NO.

IN THIS SPACE TELL WHAT IS WRONG  
AND WHAT SHOULD BE DONE ABOUT IT:

TEAR ALONG PL

TEAR ALONG PL

PRINTED NAME, GRADE OR TITLE, AND TELEPHONE NUMBER

SIGN HERE:

FILL IN YOUR  
UNIT'S ADDRESS

FOLD BACK

DEPARTMENT OF THE ARMY

OFFICIAL BUSINESS  
PENALTY FOR PRIVATE USE \$300

POSTAGE AND FEES PAID  
DEPARTMENT OF THE ARMY  
DOD 314



TEAR ALONG PERFORATED LINE

Commander  
US Army Armament Materiel Readiness Command  
ATTN: DRSAR-MAS  
Rock Island, IL 61299



**TM 9-4940-420-14&P GUN, CLEANING, PNEUMATIC, MODEL 140B2—1979**